

Breathing Better NZ Limited



AIR PURIFIER

Operating Manual

BB22 Wall Mounted Purifier

- Thank you for purchasing our product, please carefully read the operating manual before use
- If you have any questions, please contact us at info@breathingbetter.co.nz

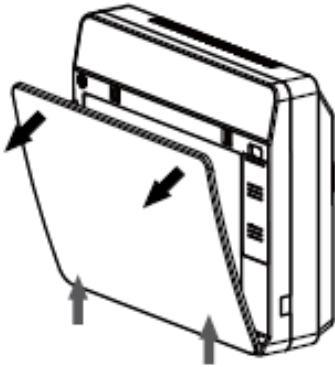

1. Remove all packaging from the unit.
2. Place on a flat stable surface.
3. Hold the top of the unit with one hand.
4. With your other hand, gently pull the display panel out from the top to a 45-degree angle.
5. Lift the display panel up to remove it from the unit.

5. Remove all packaging from the filter
6. With the pull tabs towards the front, gently place the filter into the unit.
7. Apply gentle pressure to insert the filter into the unit.

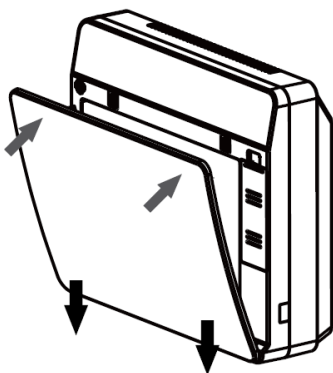
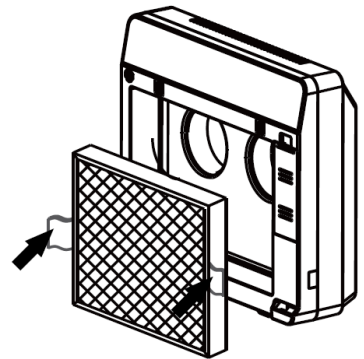

8. Replace the display panel by inserting the bottom buckles into the holes at the bottom on the front cover.
9. Move the top of the display panel into the holes at the top of the front cover.
10. Gently press the display into place. You will hear the Display Panel 'click' into position.
11. Connect the supplied power cable to the unit, then to your power outlet.

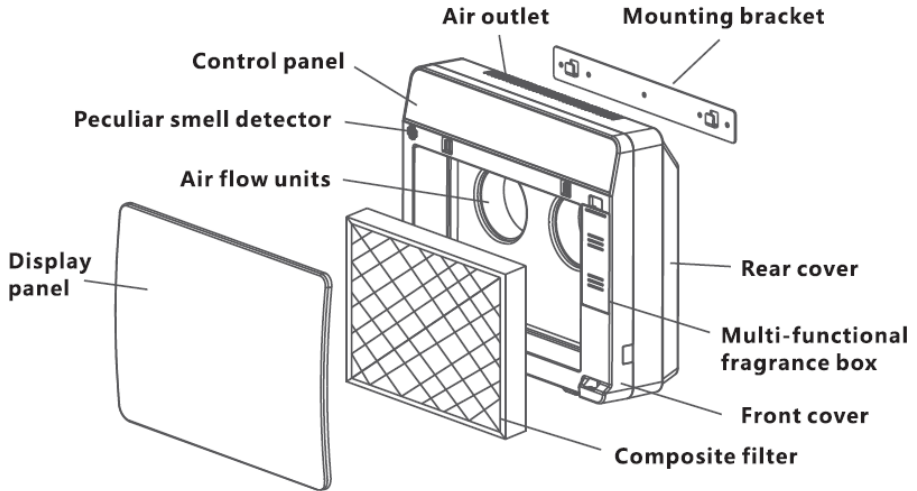

Multi-functional fragrance box

You can insert fragrances into the large multi-functional fragrance box to immediately fill your room with healthy and fresh smells.

Examples of items that can be used: Bottled perfume, agalwood, fragrance beads, dried flowers, etc.

Do not use liquids in the fragrance box, only use dried or solid fragrant materials.

Mounting your Air Purifier

Only use the brackets provided to mount onto the wall.

Ensure you are securing the bracket to wall or surface that can support it. If required, use screw anchors that support at least 2.5kg weight in the wall to secure the bracket.

Once the bracket is secure, you can slide the unit onto the bracket, aligning the holding slots together.

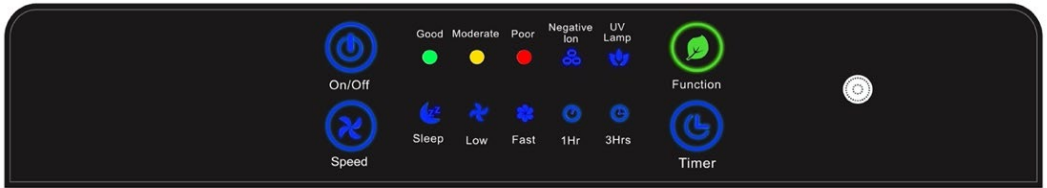

Turn on/off: Lightly touch 'On/Off' to start the purifier. Touch 'On/Off' again to turn the purifier off.



Air speed: Lightly touch the 'Speed' button to move between the 3 speed modes.



Sleep mode: suggested for use at night while sleeping. The backlight turns off and fan placed into low speed



Low mode: This is default speed setting for the unit, designed for normal everyday use.



Fast Mode: Use Fast Speed to purify when obvious air pollution or peculiar smells are in the room.



Timer: Lightly touch the 'Timer' button to turn on the auto-off function.

- Touch once to set the unit to turn off in 1 hour.
- Touch again to set to unit to turn off in 3 hours.
- Touch again to turn off the auto-off function.



1Hr

3Hrs



Function: Lightly touch the 'function' button to turn on/off the UV Lamp which can sterilise the air passing through the unit. When on, the UV Lamp symbol is illuminated.



Negative Ion: While the unit is on, the negative ion symbol is illuminated to indicate the module is working. Negative ions are emitted for 20 minutes then it stops for 5 minutes. The cycle then repeats for as long as the unit is turned on.

Automatic air quality detection

The unit is equipped with built-in highly sensitive 'peculiar smell' sensor that detects the air quality immediately after starting up.



When the air quality is good, the 'Good' indicator is illuminated.

The moderate indicator illuminates when the air quality is moderate.

When the air quality is 'bad' the unit switches to 'fast mode' and locks the setting until the air quality returns to 'Good' or 'Moderate', when it unlocks from 'Fast mode'.

Remote Control: The unit comes with an Infra-red remote control that can be used up to 4-5 meters from the unit. Point the IR Remote at the receiving sensor on the unit, located on the right of the control panel.

Filter Care and Replacement

Every 2-3 weeks remove the display panel and use a soft brush to gently brush the front of the filter to remove any larger particulates that have been captured.

Replacing Air Purifier Filter

The filter should be changed approximately every 6 months to maintain the effectiveness.

To let you know the filter needs to be replaced, the three air quality indicators flash simultaneously and the unit emits a chirping sound.

Good Moderate Poor



Only use the filters supplied or provided by **Breathing Better NZ** in your Air Purifier.

Your Air Purifier Filters are: **BB22F Wall Mounted Filter**

Order your replacement filters online at www.breathingbetter.co.nz or email us at info@breathingbetter.co.nz

Once you have replaced the filter with a new one, lightly touch and hold the 'Timer' and 'Speed' buttons for 5 seconds to reset the warning.

Cleaning your Air Purifier

- Turn off the unit and unplug the power cord.
- Clean the outside of the unit with a soft dry cloth.
- Use a soft brush to clean the air intake and outlet

Please check this table for before contacting us should your unit not be working as described.

Problem	Possible Cause	Try this...
The unit is not working	Power cord is not plugged in/there is no electricity	Plug in the power supply / check the power supply is working
	Unit is not turned on	Touch the 'On/Off' button
The purification effect is poor	Air inlet/outlet is blocked	Clean the filter using a soft brush to remove particulates.
	Wrong installation of the filter direction	Reinstall the filter the correct way.
	The filter is too dirty	Replace the filter
Air volume is small	Filter may be dirty	Replace the filter
	Packaging not removed	Ensure all packaging is removed
Abnormal noise from unit	Ensure all packaging is removed and check for damage to the unit	
	Ensure the air inlet and outlet is not blocked by anything, and clean it if needed.	
	While the negative ion function is on, "fizz" sound is normal.	

If above corrective actions do not solve the problem, please contact Breathing Better NZ. For safety, please do not disassemble the unit and maintain by yourself to avoid damage.



Breathing Better NZ Limited

46 Galloway Road,
RD 1, Papakura 2580
New Zealand



021 02788465

info@breathingbetter.co.nz



www.breathingbetter.co.nz

To avoid causing injury to anyone, users must strictly follow the safety guide. Meaning of all warning symbols is specified below.









Neglect or misinterpret these warning symbols will cause the following situations:

	Warning	The content of this symbol indicates “may cause bodily injury to people or death” .
	Attention	The content of this symbol indicates “may cause bodily injury to people and damage to properties” .

Classified symbols to specify issues that must be strictly followed:

	Prohibited matters
	Compulsory matters
	Matters need to pay attention



Warning



 <p>Do not contact the power cord with wet hands.</p> <p>Do not contact with wet hands!</p> <p>It may cause electric shock!</p>	 <p>Always unplug the unit before cleaning.</p> <p>Unplug!</p> <p>Otherwise, the unit may start functioning and cause electric shock.</p>
 <p>Do not connect to power source, adaptor socket power source or connection device exceed specified voltage limit. Use DC5V \geq 2A only .</p> <p>Prohibited!</p> <p>Using adaptor socket or power connection device exceed specific voltage limit will cause overheat to power cord and cause fire hazard.</p>	 <p>Make sure that you plug the appliance properly into a power socket. If the power cord plug is not completely plugged into a power outlet, this may cause overheat and result in electric shock and fire hazard.</p> <p>Compulsory!</p> <p>Do not use a damaged plug or any power socket which cannot securely hold/does not fit the power cord plug.</p>
 <p>Do not damage power cord or power socket.</p> <p>Prohibited!</p> <p>Do not cut or scratch with sharp object; Do not alter, overfold, exceedingly stress, over-twist the power cord; do not sit heavy object(s) or squash the power cord. Using a damaged power cord may cause electric shock or fire hazard. Contact a qualified service center for power cord and plug repair and maintenance.</p>	 <p>Please clean the plug regularly. Dusts and moisture may damage the insulation area of the plug and causes fire hazard.</p> <p>Compulsory!</p> <ul style="list-style-type: none"> - pull out the plug and clean with dry cotton swab. - always unplug the unit if you do not intend to use for a long period of time.
 <p>Do not move the unit by pulling its power cord.</p> <p>Prohibited!</p> <p>Otherwise, it may cause short circuit or wire damage, result in fire hazard or electric shock.</p>	 <p>Do not exceedingly stress the power cord while using the unit.</p> <p>Prohibited!</p> <p>Otherwise, it may cause short circuit or wire damage, result in fire hazard or electric shock.</p>

Warning

 <p>Do not let water or any other liquid enter the unit.</p> <p>Do not spray liquid on the unit!</p> <p>To avoid electric shock!</p>	 <p>Do not attempt to disassemble or do alteration/modification to the unit.</p> <p>Prohibited!</p> <p>Unauthorized disassembling or alteration/modification may cause malfunction or fire hazard. Customer should contact authorized service provider to repair the unit.</p>	 <p>Do not block the air inlet and outlet, e.g. by placing bar shape or metal object.</p> <p>Prohibited!</p> <p>The foreign object may touch the inside parts causes electric shock or injury.</p>	 <p>Do not insert fingers or objects into the air outlet or the air inlet to prevent bodily injury.</p> <p>Be cautious of the product's orientation</p>
--	---	---	--

Attention !

 <p>Do not use the unit in wet surroundings or in surroundings with high ambient temperatures, humidity or in an area where the unit will possibly be immersed by water, such as the bathroom, toilet, or kitchen.</p> <p>Do not let liquid get into the unit!</p> <p>To avoid electricity leakage, electric shock or fire hazard.</p>	 <p>Do not use alcoholic or dilute solvent, do not spray any flammable materials such as insecticides around the unit.</p> <p>Prohibited!</p> <p>These may damage the unit, causes injury, circuit short, electric shock or fire hazard.</p>	 <p>Do not use the unit in places of oily residues.</p> <p>Prohibited!</p> <p>Otherwise, this may damage the unit and cause injury. This air purifier is not a substitute of proper ventilation.</p>
--	---	---

 <p>Do not let flammable materials, such as fragrance or burning incense enter the unit.</p> <p>Keep away from flame fire!</p> <p>Otherwise, it may cause fire hazard.</p>	 <p>Do not use this appliance when you have used indoor smoke-type insect repellents, burning incense, or chemical fumes.</p> <p>Prohibited!</p> <p>Otherwise, chemical substances may reside inside the unit and release through air outlet which will cause health hazard. Ensure thorough air ventilation is available in areas where pesticide is used previously indoor before using this unit.</p>	 <p>If both heater and air purifier operate within the same enclosed area, please ensure proper air ventilation is maintained in the area.</p> <p>Compulsory!</p> <p>Otherwise, it will cause carbon monoxide poisoning. This unit is unable to clear carbon monoxide.</p>
---	--	--

Thank you for purchasing your Air Purifier from **Breathing Better NZ Limited**.

Your **12-month Warranty** for this unit was automatically registered when you purchased it and starts 30 days from that date.

Read this warranty carefully and keep in a safe place.

- 1) For repairs to your unit, please contact us at info@breathingbetter.co.nz and we will advise you of the nearest authorised repairer to contact.
- 2) This warranty does not cover damage caused by:
 - a. mistreatment of the unit. Examples are: Dropped unit, damage caused by moisture.
 - b. natural disaster. Examples are Earthquake, Flooding, bush fire, and other natural disasters.
 - c. using an unauthorised repairer.
 - d. incorrect use that is not following the operating instructions.
- 3) Damage to the Glass Control Panel is excluded from the warranty.
- 4) Damage caused outside the warranty period is not covered.
(Note: if any of the above are the cause of damage, please contact us and we can refer you to your nearest repair. This will be at your cost)
- 5) Before returning your Air Purifier ensure there is no damage to the exterior of the unit, any included accessories, and the package overall.

For all warranty questions or claims, please contact us:

Breathing Better NZ Limited

46 Galloway Road,
RD 1, Papakura 2580
New Zealand

Ph: 021 02788465

Email: info@breathingbetter.co.nz

Web: www.breathingbetter.co.nz